

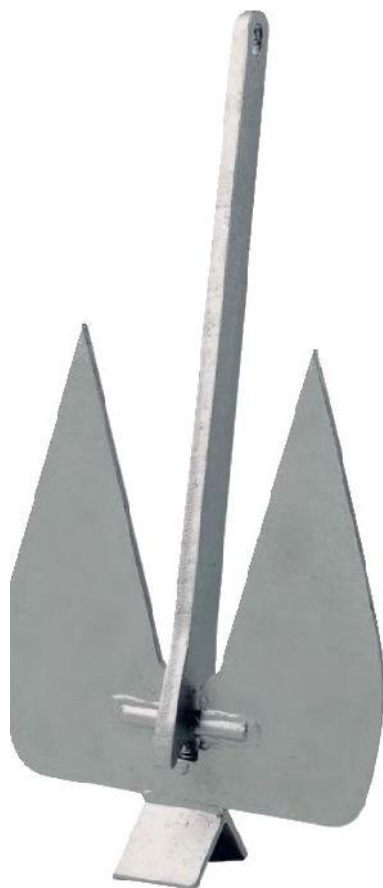

NORFOLK MARINE

Church Road, Wroxham, Norwich, Norfolk NR12 8UG Tel: 01603 783393 / 783150 Fax: 01603 782471
sales@norfolkmarine.co.uk www.norfolkmarine.co.uk

BRITANY ANCHOR



Instant biting into the sea bed:

- To prevent potential fouling, the Brittany has no large crown
- To avoid clogging by pebbles, the Brittany has no link cage
- Thin flukes with sharp edges: ensures quick digging even in the hardest sea beds
- Geodynamic flukes, ensuring easy burial and perfect holding
- High resistance shank, cast in one piece: gives perfect resistance even to a strong lateral pull
- Narrow crown, designed to lift the rear of the anchor, so that the flukes dig in immediately



The Brittany is the only flat anchor with a shank designed not to four, thus preventing the anchor from breaking away. It bites into the sea bed within seconds.

Boat length	Weight		A	B
	kg	lb	mm	mm
Dinghy, tender	2	4.4	406	185
Dinghy, small catamaran	3.5	7.7	497	219
5.5m	6	13	547	270
6.5m	8	17.6	646	312
7.5m	10	22	732	347
9m	12	26.5	786	347
10.5m	14	30.8	788	368
12.5m	16	35.3	841	368
16m	20	44	910	414
18m	25	55	970	451
20m	35	77	1038	522
25m	45	100	1085	550
+25m	65	143.3	1197	594
	90	198.5	1292	666

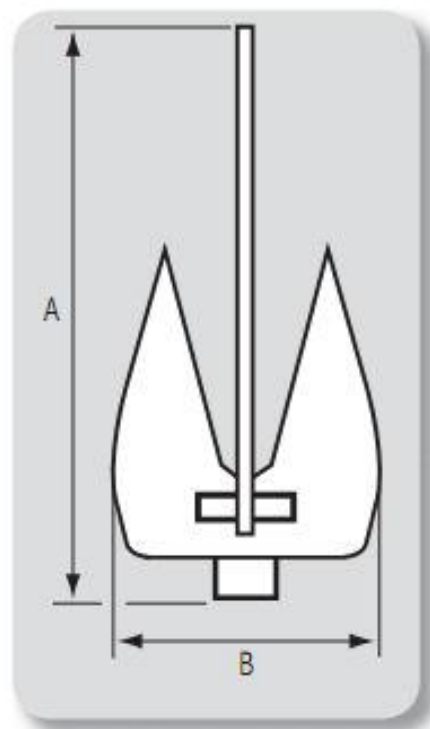

Anchor weight per boat length is only given as an indication. However, your anchor selection should also recognise the specific construction of your vessel.



NORFOLK MARINE

Church Road, Wroxham, Norwich, Norfolk NR12 8UG
sales@norfolkmarine.co.uk

Tel: 01603 783393 / 783150 Fax: 01603 782471
www.norfolkmarine.co.uk

FHD ANCHOR



Galvanised steel:

Thermal treatment increases the breaking resistance



Stainless steel 316 (to order):

Dipped in decontaminating fluid, totally impervious to corrosion

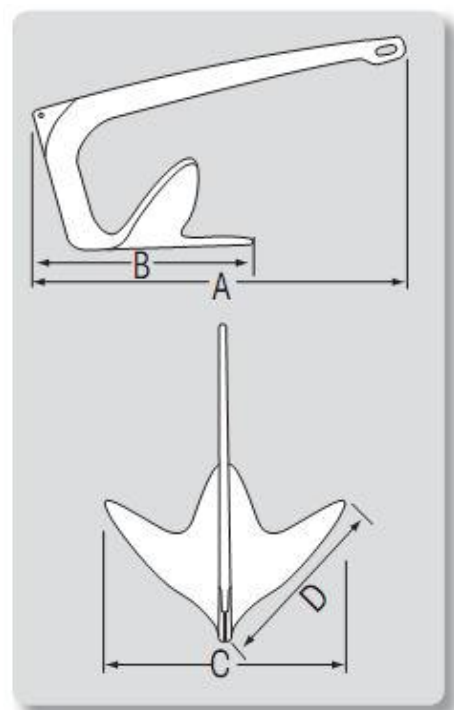

Boat length	Weight		Galvanised				Stainless steel			
	kg	lb	A	B	C	D	A	B	C	D
			mm	mm	mm	mm	mm	mm	mm	mm
3.5m	2	4.5	350	140	195	130	360	140	190	130
5m	5	11	470	260	300	215	440	255	310	210
6.5m	7.5	17	470	300	330	240	450	285	340	240
7.5m	10	22	520	315	370	265	520	315	375	270
10.5m	15	33	620	365	440	320	615	355	440	310
16m	20	44	690	390	450	330	650	395	460	330
19m	30	66	810	425	520	380	765	450	515	375

The anchor weight can be subject to variations due to the manufacturing process.



NORFOLK MARINE

Church Road, Wroxham, Norwich, Norfolk NR12 8UG
sales@norfolkmarine.co.uk

Tel: 01603 783393 / 783150 Fax: 01603 782471
www.norfolkmarine.co.uk

SOC ANCHOR

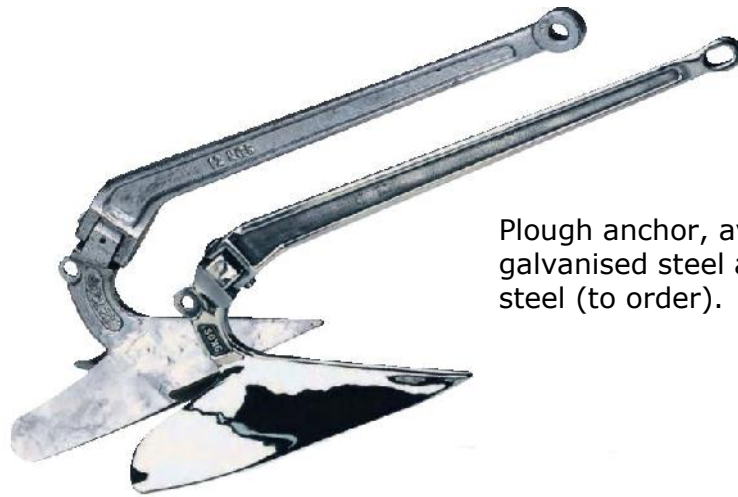

Plough anchor, available in hot dipped galvanised steel and in 316L stainless steel (to order).

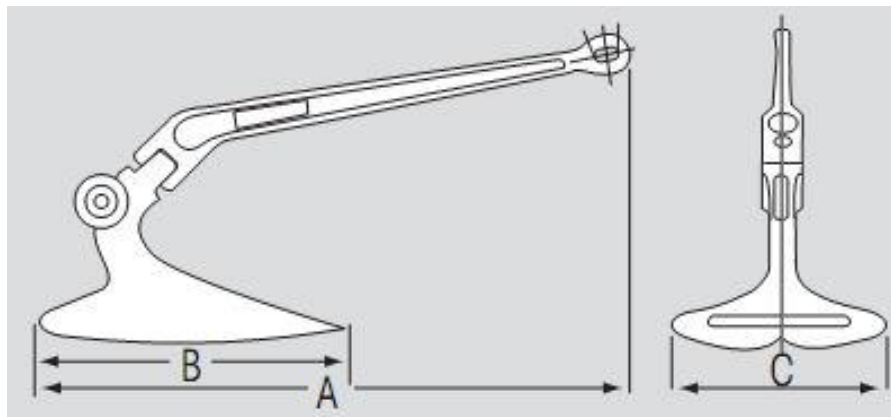

Boat length	Weight		Galvanised			Stainless steel		
	kg	lb	A	B	C	A	B	C
			mm	mm	mm	mm	mm	mm
5.5m	7	15	750	400	250	650	345	228
6.5m	9	20	800	410	270	790	405	272
9m	12	25	930	440	305	830	425	290
12.5m	15	32	970	480	320	860	450	290
17m	22	45	1000	517	360	870	468	322
18m	27	60	1080	670	420	895	490	335

The anchor weight can fluctuate slightly due to the manufacturing process.



NORFOLK MARINE

Church Road, Wroxham, Norwich, Norfolk NR12 8UG
sales@norfolkmarine.co.uk

Tel: 01603 783393 / 783150 Fax: 01603 782471
www.norfolkmarine.co.uk

GRIP ANCHOR

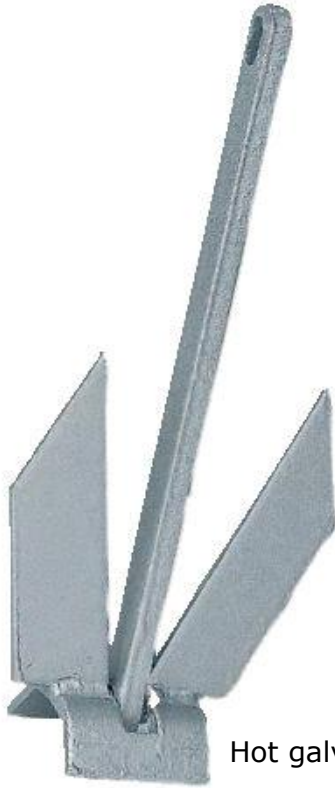

Hot galvanized steel.

Weight	Length
2.5kg	353mm
5kg	445mm
7kg	543mm
9kg	588mm

FOLDING GRAPNEL WITH SPOON FLUKES

Weight	Length
1.5kg	300mm
2.5kg	360mm
3.2kg	410mm
4kg	450mm
6kg	550mm
8kg	570mm



Hot galvanized steel.